

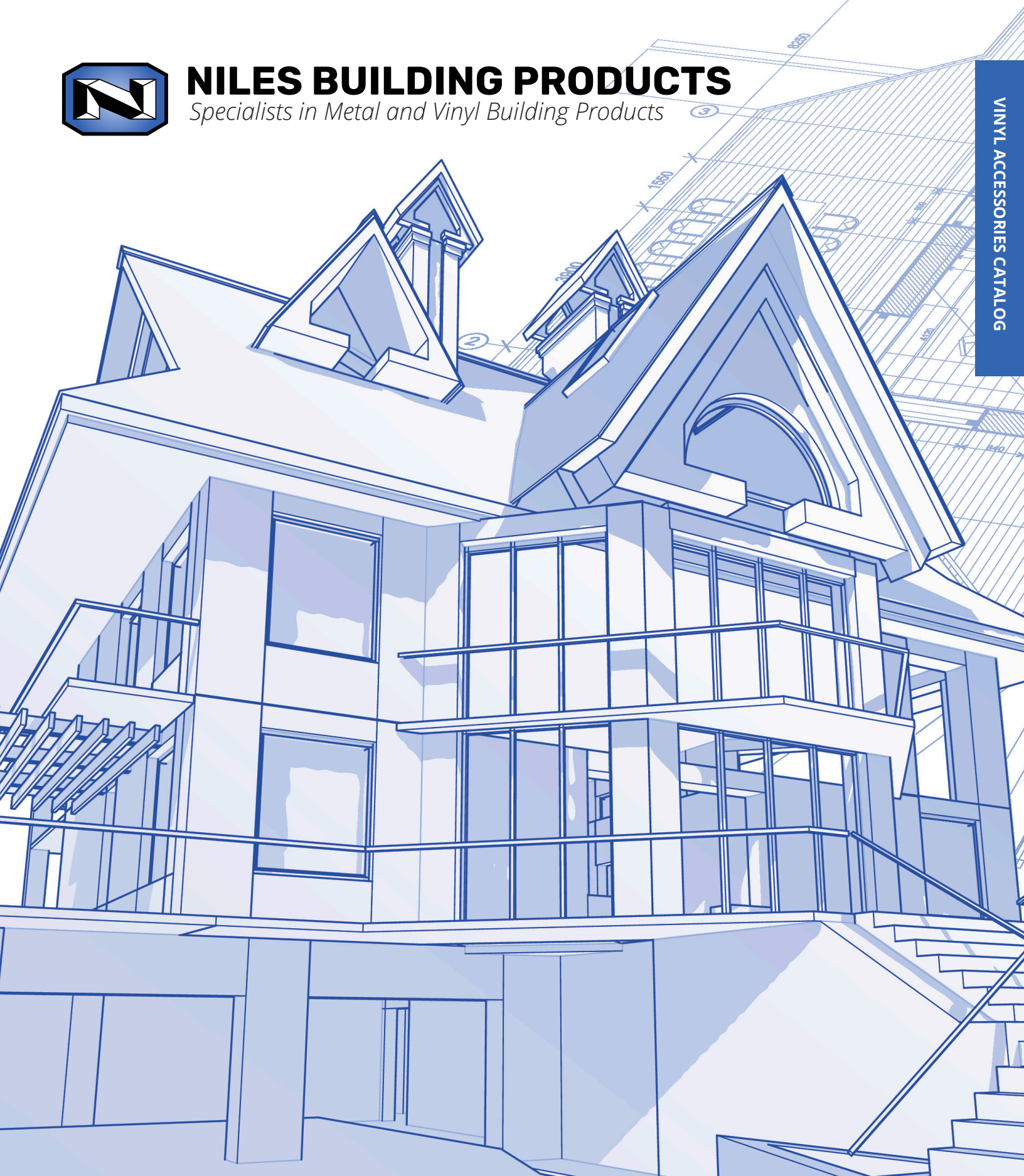

# NILES BUILDING PRODUCTS

*Specialists in Metal and Vinyl Building Products*

VINYL ACCESSORIES CATALOG



**Niles Facility**  
1600 Hunter Street  
Niles, OH 44446

**Jacksonville Facility**  
8441 Western Way  
Jacksonville, FL 32256

**Dallas-Fort Worth Facility**  
2303 I-30 Frontage Road Ste 100  
Grand Prairie, TX 75050

[nilesbldg.com](http://nilesbldg.com) • 800-323-3329



# About Niles Building Products

We are the industry leader in manufacturing expanded metal and vinyl accessories for stucco, plaster, drywall and veneer plaster applications.



JACKSONVILLE, FL



NILES, OH

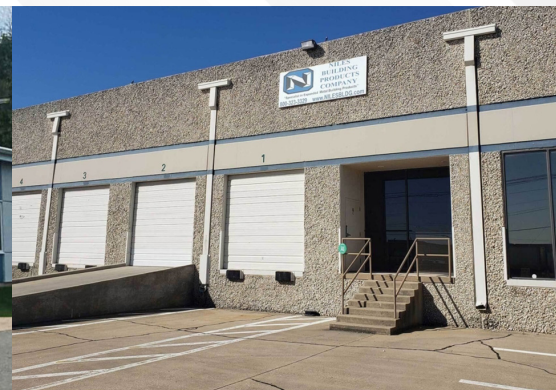

DALLAS-FORT WORTH, TX

Incorporated in Niles, OH in 1973 with just one production line and four employees, Niles Building Products has grown to become an industry leader in expanded metal and vinyl accessories—with manufacturing facilities in Niles, OH, Jacksonville, FL and Grand Prairie, TX.

Niles Building Products is a service-oriented company, focused on high quality products while maintaining low overhead. Our distinction and reputation in the walls and ceilings industry are defined by the personal attention we give every inquiry and order.

Expanded metal and vinyl building products are our specialty. Our skills and experience are the key to manufacturing products that maintain the exemplary quality levels our customers expect and depend upon. Our customers have come to depend on us to provide high quality products, competitively priced and delivered in a timely fashion. Make Niles Building Products your first choice in expanded metal and vinyl products.





# Table of Contents

## EIFS/DIRECT APPLIED

Niles Vinyl EIFS Casing/Starter	page 4
Niles Vinyl Window/Door Drip Edge	page 4
Niles Vinyl 093 Control Joint	page 5
Niles Vinyl Direct Applied Casing/Starter	page 5

## STUCCO ACCESSORIES

Niles Vinyl No. 66X Expanded Flange Casing Bead	page 6
Niles Vinyl Reinforced No. 66X Expanded Flange Casing Bead	page 6
Niles Vinyl 1-A Corner Bead	page 6
Niles Vinyl 1-A Corner Bead 4" Wing	page 7
Niles Vinyl 1-A Corner Bead Unequal Leg	page 7
Niles Vinyl Double 'V' Expansion Control Joint	page 8
Niles Vinyl Midwall	page 8
Niles Masonry Weep Screed PF	page 9
Niles Vinyl #7 FHA Foundation Weep Screed	page 9
Niles Vinyl #7 FHA Foundation Weep Screed Unequal Leg	page 10
Niles Vinyl 3" Continuous Soffit Vent 3/4" Ground	page 10
Niles Vinyl 3" F-Soffit 3/4" Ground	page 11

## SPECIFICATIONS

Vinyl Accessories for Stucco/EIFS	page 11
-----------------------------------	---------

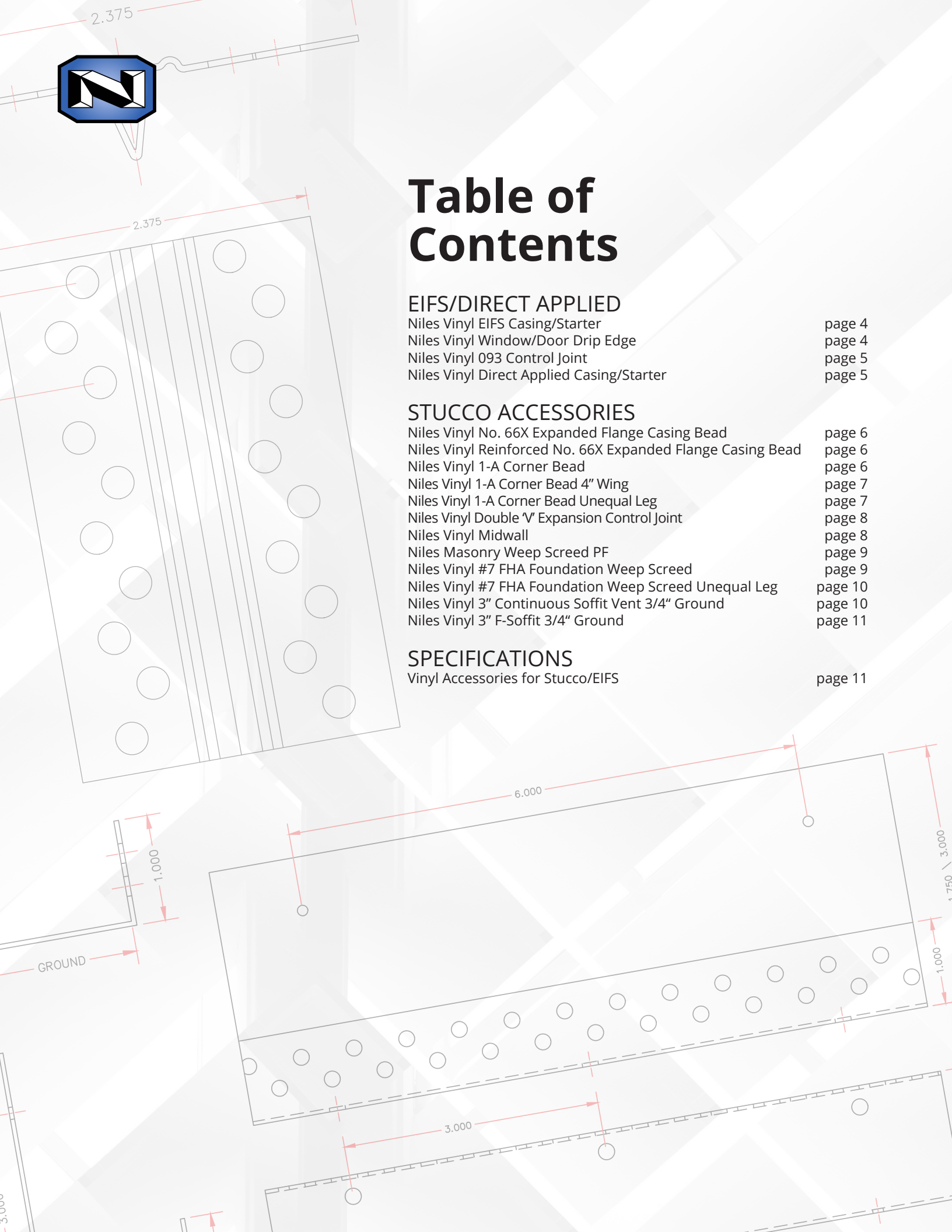

# EIFS/Direct Applied

## NILES VINYL EIFS CASING/STARTER

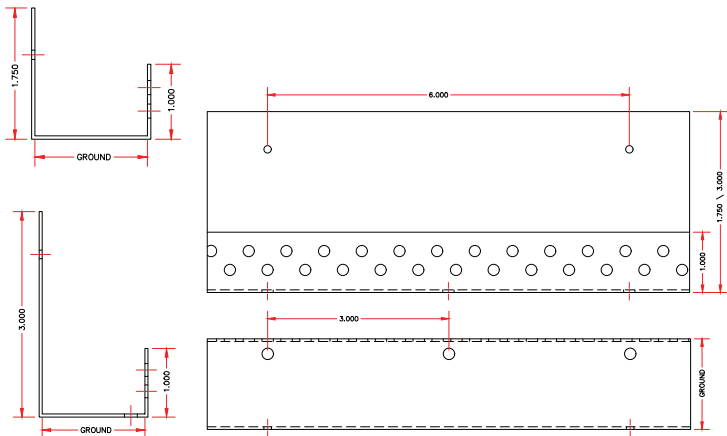

Niles Vinyl EIFS Casing/Starter is to be used at the base of the wall for EIFS applications. They may also be used as an EIFS casing bead around window and door openings.

NILES VINYL EIFS CASING/STARTER	ATTACHMENT FLANGE	PCS/ CRTN	CRTNS/ PALLET
1"	1-3/4"	40	25
1-1/2"	1-3/4"	40	25
2"	1-3/4"	30	25
1"	3"	25	25
1-1/2"	3"	20	25
2"	3"	15	25

10' LENGTHS

## NILES VINYL WINDOW/DOOR DRIP EDGE

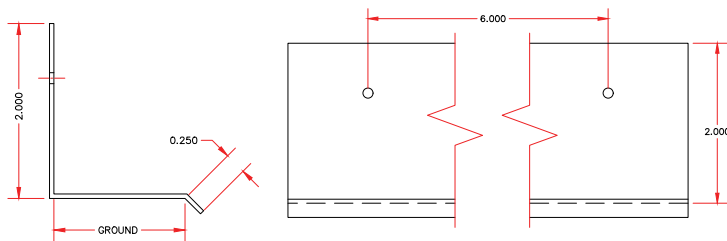

Niles Vinyl Window/Door Drip Edge is used above window and door openings to allow moisture to travel down the surface and not enter into the framing.

NILES VINYL WINDOW/DOOR DRIP EDGE	ATTACHMENT FLANGE	PCS/ CRTN	CRTNS/ PALLET
1"	2"	75	25
1-1/2"	2"	60	25
2"	2"	50	25

10' LENGTHS

## NILES VINYL 093 CONTROL JOINT

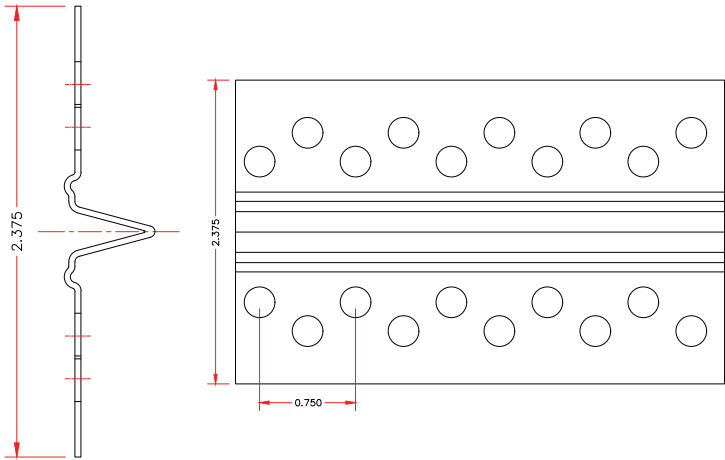

NILES VINYL 093 CONTROL JOINT	PCS/CRTN	CRTNS/PALLET
1/2"	60	25

10' LENGTHS

Niles Vinyl 093 Control Joint is used to relieve stress caused by expansion and contraction within the system.

## NILES VINYL DIRECT APPLIED CASING/STARTER

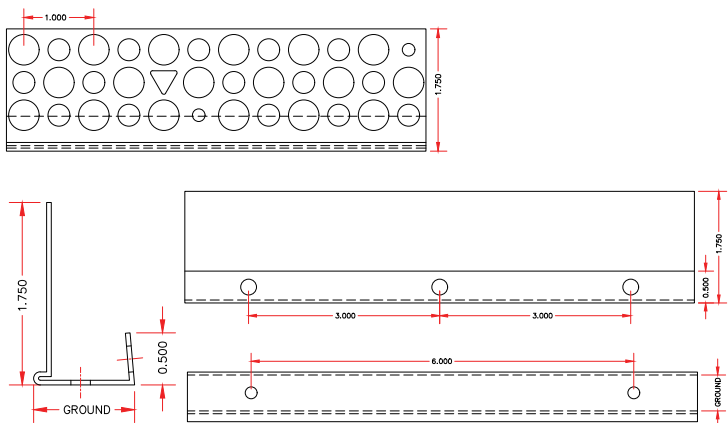

NILES VINYL DIRECT APPLIED CASING/STARTER	ATTACHMENT FLANGE	PCS/CRTN	CRTNS/PALLET
1/2"	1-3/4"	60	25
5/8"	1-3/4"	60	25

10' LENGTHS

Niles Vinyl Direct Applied Casing/Starter may be used in direct applied applications at the base of the wall as a starter track or around windows as a casing bead.

# Stucco Accessories

## NILES VINYL NO. 66X EXPANDED FLANGE CASING BEAD

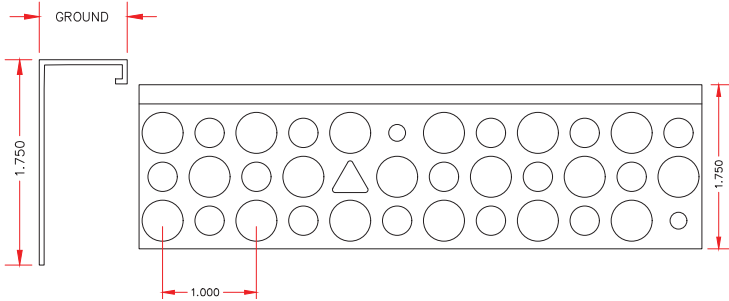

Niles Vinyl No. 66X Expanded Flange Casing Bead is used to effectively terminate plaster edge and/or to separate stucco from doors, windows and dissimilar materials.

NILES VINYL NO. 66X EXPANDED FLANGE CASING BEAD	PCS/CRTN	CRTNS/PALLET
1/2"	100	25
5/8"	100	25
3/4"	75	25
7/8"	75	25

10' LENGTHS

## NILES VINYL REINFORCED NO. 66X EXPANDED FLANGE CASING BEAD

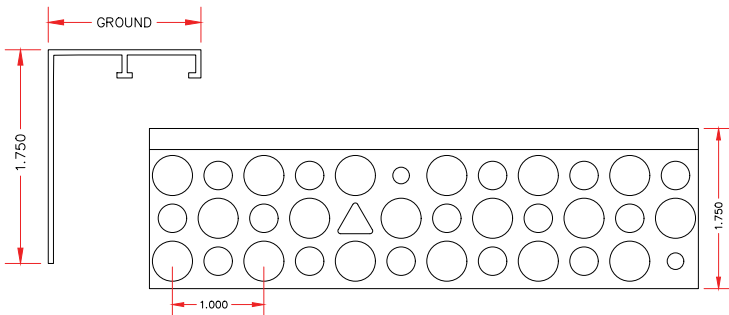

Niles Vinyl Reinforced No. 66X Expanded Flange Casing Bead is designed with a reinforced rib in the ground to assist in keying heavier and/or thicker stucco applications.

NILES VINYL REINFORCED NO. 66X EXPANDED FLANGE CASING BEAD	PCS/CRTN	CRTNS/PALLET
1"	75	25
1-1/4"	50	25
1-1/2"	50	25
2"	40	25

10' LENGTHS



## NILES VINYL 1-A CORNER BEAD

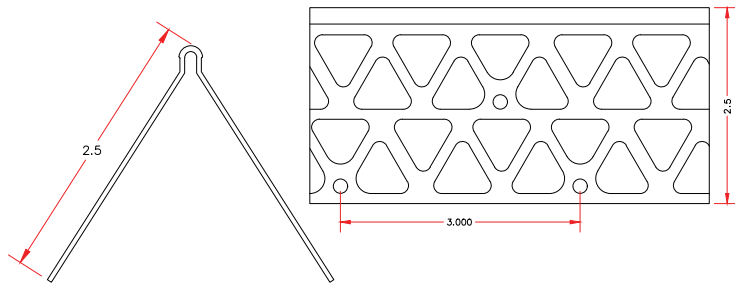

NILES VINYL 1-A CORNER BEAD STANDARD 2-1/2" X 2-1/2"	PCS/CRTN	CRTNS/PALLET
10'	50	25

Niles Vinyl 1-A Corner Bead provides a rust-proof, high-impact-resistant corner for exterior stucco applications.

## NILES VINYL 1-A CORNER BEAD 4" WING

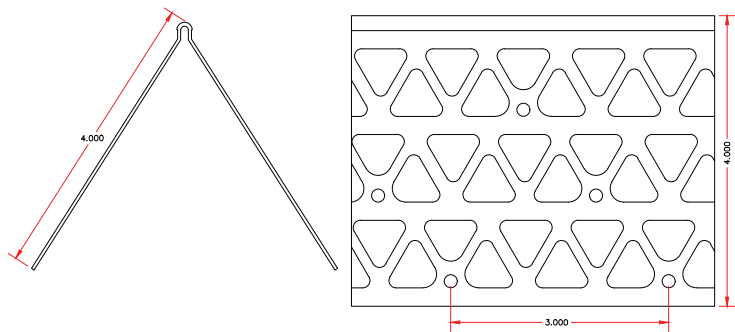

NILES VINYL 1-A CORNER BEAD 4" WING	PCS/CRTN	CRTNS/PALLET
10'	30	25

Niles Vinyl 1-A Corner Bead 4" Wing is designed for applications with deep fills or irregular corner conditions.

## NILES VINYL 1-A CORNER BEAD UNEQUAL LEG

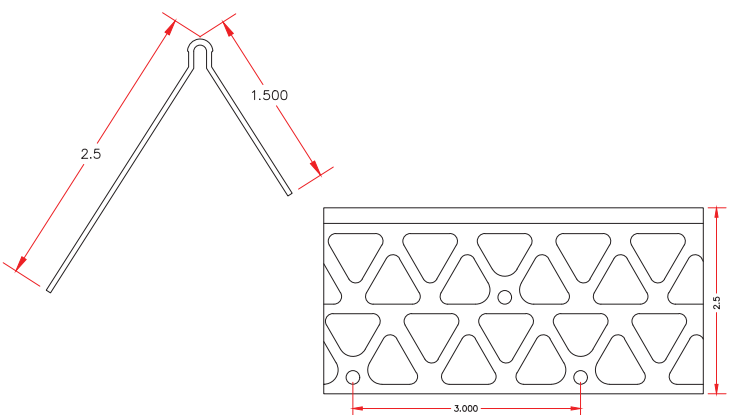

NILES VINYL 1-A CORNER BEAD UNEQUAL LEG 1-1/2" X 2-1/2"	PCS/CRTN	CRTNS/PALLET
10'	50	25

Niles Vinyl 1-A Corner Bead Unequal Leg has a 1-1/2" flange for narrow returns and for use around windows or decorative applications.

## NILES VINYL DOUBLE 'V' EXPANSION CONTROL JOINT

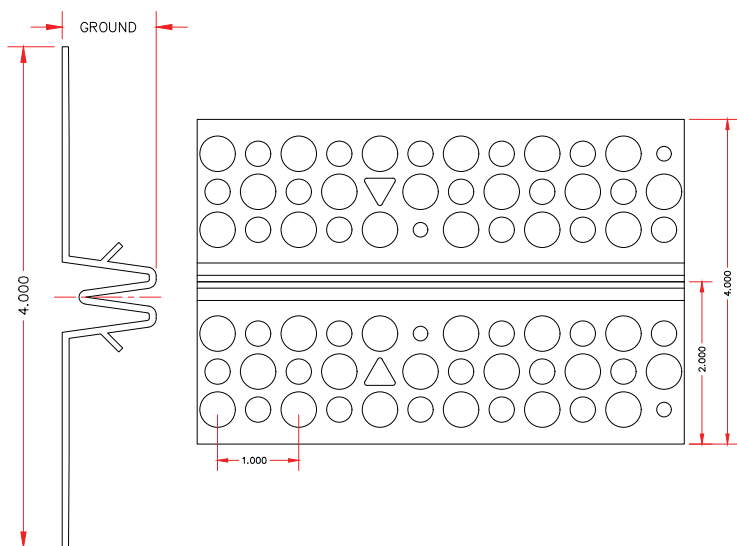

NILES VINYL DOUBLE 'V' EXPANSION CONTROL JOINT	PCS/CRTN	CRTNS/PALLET
1/2"	35	25
5/8"	30	25
3/4"	30	25
7/8"	20	25

10' LENGTHS

Niles Vinyl Double 'V' Expansion Control Joint used as a mechanism for movement to accommodate expansion and contraction caused by initial stucco shrinkage and minor thermal movement.

## NILES VINYL MIDWALL

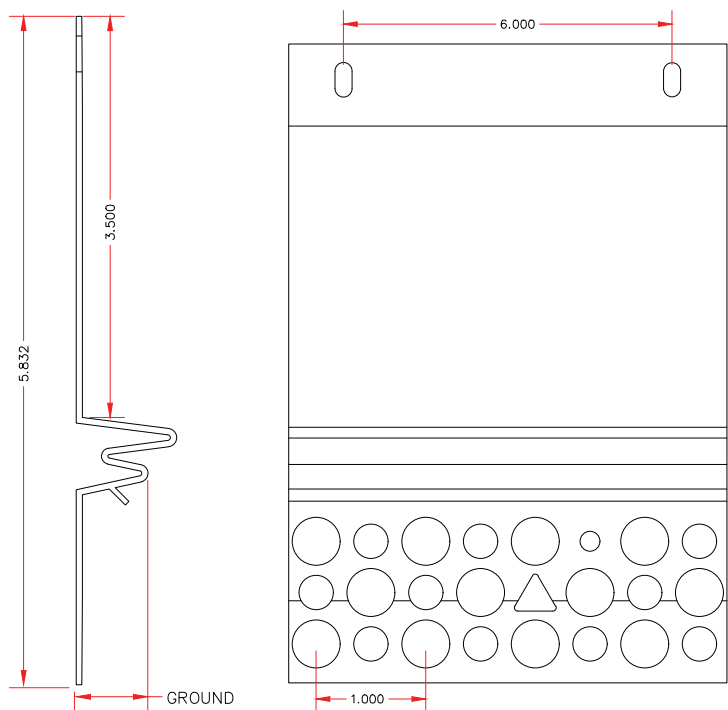

NILES VINYL MIDWALL	PCS/CRTN	CRTNS/PALLET
1/2"	15	25
5/8"	15	25

10' LENGTHS

Niles Vinyl Midwall is used where two dissimilar materials meet, such as concrete block first floor and wood framing second floor.



### NILES MASONRY WEEP SCREED PF (WITH PUNCHED FLANGE)

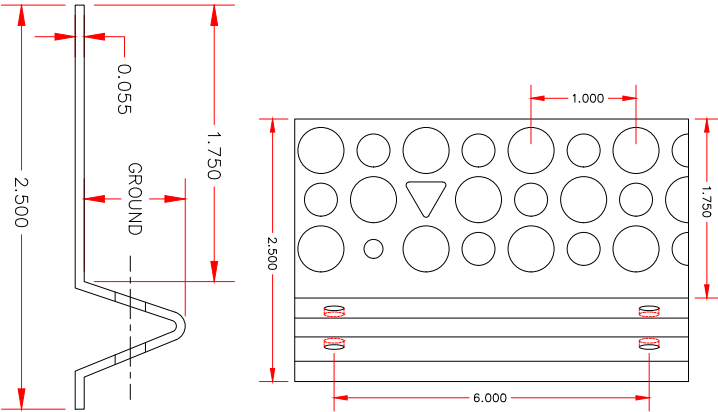

NILES MASONRY WEEP SCREED PF	PCS/CRTN	CRTNS/PALLET
1/2"	70	25
5/8"	70	25

10' LENGTHS

Niles Masonry Weep Screed PF is to be installed on masonry construction. It is designed to help direct moisture from stucco while providing a plaster stop to cleanly end stucco application.

### NILES VINYL #7 FHA FOUNDATION WEEP SCREED

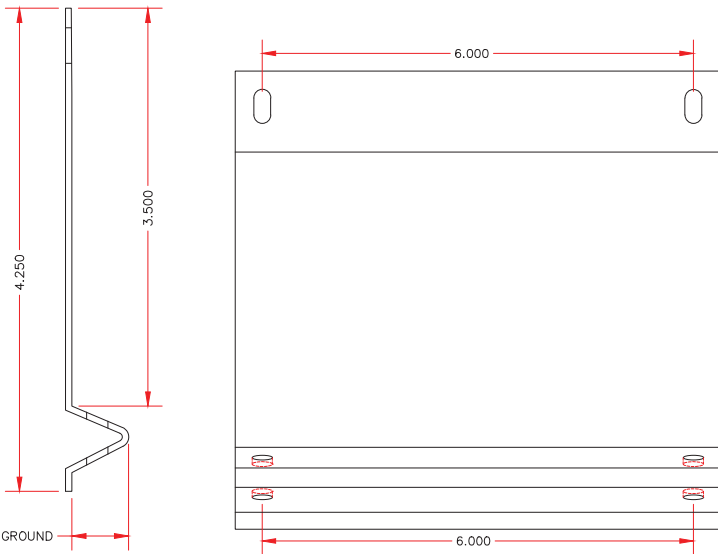

NILES VINYL #7 FHA FOUNDATION WEEP SCREED	PCS/CRTN	CRTNS/PALLET
1/2"	35	25
5/8"	35	25
3/4"	35	25
7/8"	30	25

10' LENGTHS

Niles Vinyl #7 FHA Foundation Weep Screed is manufactured to provide both a ground for plaster finishes and weep holes to allow for moisture to drain properly from the exterior plaster system.

## NILES VINYL #7 FHA FOUNDATION WEEP SCREED UNEQUAL LEG

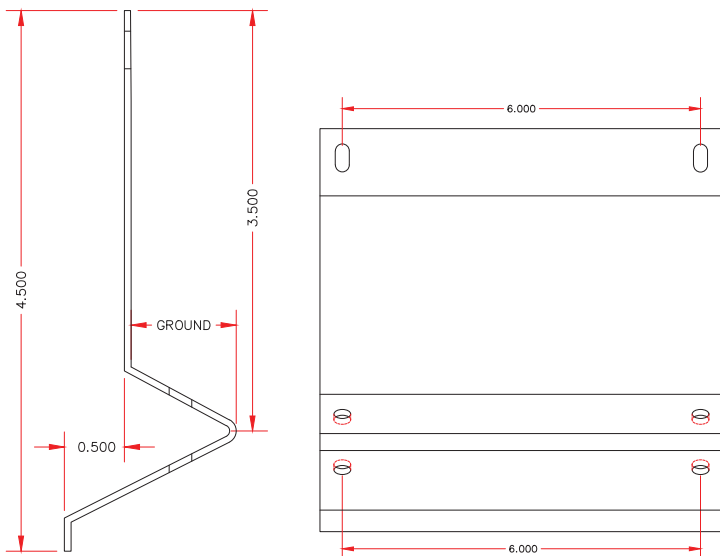

NILES VINYL #7 FHA FOUNDATION WEEP SCREED UNEQUAL LEG	PCS/CRTN	CRTNS/PALLET
7/8"	30	25

10' LENGTHS

Niles Vinyl #7 FHA Foundation Weep Screed Unequal Leg is produced with a longer leg to allow for added depth due to sheathing on the wall. It is used to provide a weep mechanism as part of the drainage system where stucco and foundation walls meet.

## NILES VINYL 3" CONTINUOUS SOFFIT VENT 3/4" GROUND

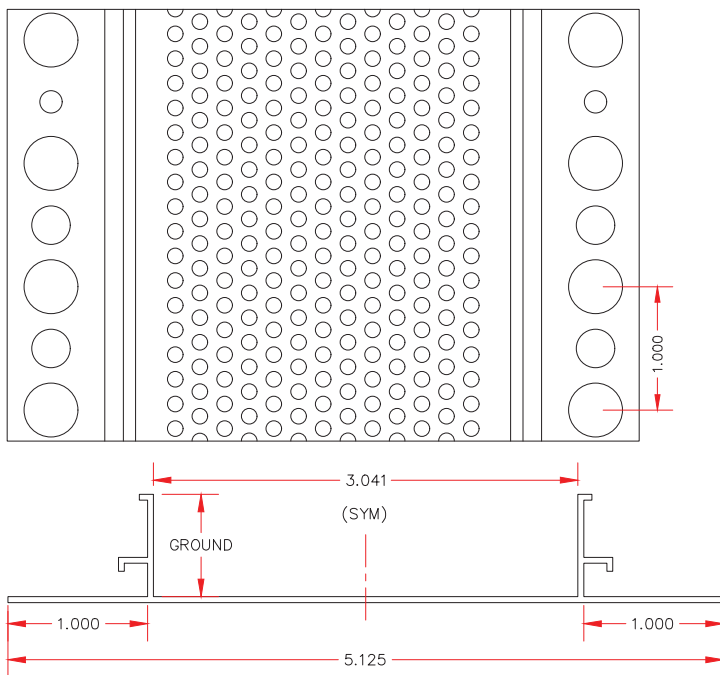

NILES VINYL 3" CONTINUOUS SOFFIT VENT	PCS/CRTN	CRTNS/PALLET
3/4"	15	25

10' LENGTHS

Niles Vinyl Continuous One-Piece Soffit Vent is designed with a reinforcing rib to aid in the keying of stucco and plaster.

# NILES VINYL 3" F-SOFFIT 3/4" GROUND

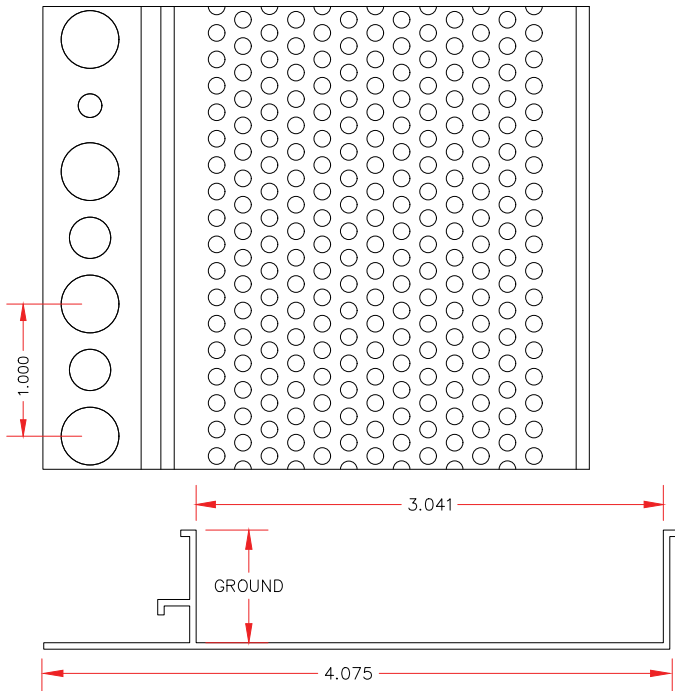

NILES VINYL 3" F-SOFFIT 3/4" GROUND	PCS/CRTN	CRTNS/ PALLET
3/4"	15	25

10' LENGTHS

Niles Vinyl F-Soffit Vent is a one-piece soffit vent with an 'F' profile that is designed with a reinforcing rib to aid in the keying of stucco and plaster.



# Specifications

## Vinyl Accessories for Stucco/EIFS

### PRODUCT NAME:

Niles Building Products Rigid Vinyl (PVC) Accessories

### MANUFACTURER:

Niles Building Products  
1600 Hunter Street  
Niles, OH 44446  
Phone: (800) 323-3329, (330) 544-0880  
Fax: (330) 544-8868

### PRODUCT DESCRIPTION:

Niles Building Products extruded vinyl accessories are manufactured for exterior stucco and interior plaster applications. Niles Building Products vinyl accessories are produced using high quality vinyl compounds. Stucco/Plaster accessories include corner and casing beads, control and expansion joints, and weep screeds.

All Niles Building Products vinyl accessories are produced from vinyl compounds that meet ASTM D-4216 and ASTM D-1784.

### PRODUCT STANDARDS

All vinyl accessories conform to ASTM C-844, ASTM C-1047 and ASTM D-1784 for interior products or ASTM D-4216, ASTM C-1063 and ASTM C-1861 for exterior stucco products.

### LEED

Niles Building Products vinyl accessories are made with a high percent of post-consumer recycled content and provide Credits MR 4.1 and 4.2 – Recycled Content. Additionally, vinyl accessories may provide credits for MR 5.1 and 5.2 – Regional Materials. Contact Niles Building Products for LEED Documentation information.

### FLAMMABILITY/FIRE RESISTANCE

Rigid vinyl is self-extinguishing and does not support combustion once the flame source is removed. Therefore, it will not cause a fire to re-start or spread. Rigid vinyl offers better resistance to burning than many other common building materials.

### PAINTING VINYL ACCESSORIES

Niles Building Products vinyl accessories have excellent paint adhesion. Accessories surface must be clear of debris and oils prior to painting. Should cleaning be necessary a mild detergent is recommended. Contact the paint manufacturer to determine surface preparation and coating recommendations prior to painting.

### INSTALLATION:

Vinyl stucco accessories shall be installed per ASTM standards and prevalent industry standards. Vinyl accessories may be fastened using lath nails, screws or wire ties as described in ASTM C-1063.

All vinyl accessories have adequate perforations that allow the complete embedment and keying of the stucco or plaster. Some accessories have surface ridges that assist in the adhesion of the stucco or plaster.

### SEALING AND CAULKING

All butt joints, intersections and ends of vinyl accessories shall be joined, embedded and sealed in a compatible sealant designed for its intended end use and compatible with the exterior paint finish. Consult caulking manufacture for specific recommendations.

### WARRANTY:

Niles Building Products vinyl accessories are warranted to the finished product specification in the referenced ASTM standards; ASTM D-1784, D-4216, C-1063, C-1861 and C-1047. This warranty is limited to one year from the date of initial purchase. Niles Building Products does not control installation, workmanship, fastening, complementary materials or climate conditions. Therefore, Niles Building Products sole responsibility under this warranty is for replacement of material only and excludes any labor or installation costs. This warranty applies to material that has been deemed defective through manufacturing only and not product that has been damaged during installation or improperly installed.

### STORAGE:

Vinyl accessories shall be protected from the elements prior to installation. Care should be taken to avoid damage to the accessories and not store items on top of them that may deform their shape before using.



